

# Valves for Water & More

*Pilot control separated  
from the medium*

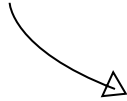

*High quality  
materials*



*Good corrosion  
resistance*



*Engineering  
GREAT Solutions*

# Contents

---

03 Valves for water & more

---

04 Valves for water treatment

---

05 Valves for drinking water applications

---

---

06-09 Special solutions

---

10 Applications

---



## Engineering GREAT solutions through people, products, innovation and service

IMI Precision Engineering is a world-leader in fluid and motion control. Building close, collaborative relationships with our customers, we gain a deep understanding of their engineering needs and then mobilise our resources and expertise to deliver distinctive products and solutions.

Wherever precision, speed and engineering reliability are essential, our global footprint, problem-solving capability and portfolio of high performance products enables us to deliver GREAT solutions which help customers tackle the world's most demanding engineering challenges.

> **Reliability**

We deliver and support our high quality products through our global service network.

> **High performance products**

Calling on a world-class portfolio of fluid and motion control products including IMI Norgren, IMI Buschjost, IMI FAS, IMI Herion and IMI Maxseal. We can supply these singly, or combined in powerful customised solutions to improve performance and productivity.

> **Partnership & Problem Solving**

We get closer to our customers to understand their exact challenges.

# Valves for water & more

Water is one of the most valuable resources on earth and treating and handling clean water responsibly is becoming increasingly crucial for consumers, the economy and governments. At IMI Precision Engineering, we have long operated in the market with awareness of its status as a critical and scarce resource.

Our magnetically driven diaphragm valves, made from brass, stainless steel and plastic, are the ideal choice for this medium and frequently used to channel incoming water or to control flow during the water treatment process.

Moreover, the materials used in the magnetic valves also meet the tightened requirements imposed by the EC Drinking Water Directive of 1 December 2013 with lead content reduced to 10µg/l, while the gasket materials tested in line with KTW recommendations ensure the valves remain ideally suited for deployment in conventional drinking water installations.

Our magnetic valves, developed in-house via a direct-operated approach, control the flow of water and steam in coffee machines, which is crucial for the famous selection of espresso, latte and macchiato drinks you enjoy. During regular servicing, these same valves also dispense cleaning agent and descaler; helping ensure coffee quality is maintained as well as meeting all relevant hygiene standards (Directive on Food). Incidentally, the design of the valve housing and the choice of PPSU for the housing material reduce the calcification risk to such an extent that the maintenance cycle can be extended 2-3 times longer than other comparable valves – tangible added value for our customers.

Further uses of IMI Buschjost valves include control and regulation in industrial settings, e.g. tempering of injection moulding machines up to the production of ultra-pure water for the semi-conductor and pharmaceutical industries. Naturally, conventional shut-off functions within piping are also provided securely and reliably by these magnetically driven diaphragm valves.

## Product highlights:

- > Good corrosion resistance
- > Pilot control separated from the medium (optional)
- > Not affected by limescale formation
- > Various options available
- > Approvals: NSF, KTW, FDA
- > Compliance with the EC Drinking Water Directive









High flow rate

Functional compact design

# Valves for water treatment

Series	Type	Operation	Orifice (mm)	Fluid temp. (Max.)	Pressure range	Material body	Features
82610 	Seat valves	Directly solenoid actuated	DN 1,5 ... 5	110°C	0 ... 40 bar	Stainless steel (1.4408) 	Optimized opening and closing time
82560 	Diaphragm valves	Solenoid actuated, with forced lifting	DN 10	90°C	0 ... 10 bar	Stainless steel (1.4408), PA 66 	Compact design by high flow rate
82730 <i>Click-on</i> 	Diaphragm valves	Indirectly solenoid actuated	DN 8 ... 50	90°C	0,1 ... 16 bar	Stainless steel (1.4408) 	Optional: Medium isolated by pilot control
82590 <i>Click-on</i> 	Diaphragm valves	Solenoid actuated, with forced lifting	DN 8 ... 50	90°C	0 ... 16 bar	Stainless steel (1.4408) 	For systems with low or fluctuating pressure
82080 	Seat valves	Directly solenoid actuated	DN 3 ... 8	110°C	0 ... 7 bar	PVDF	Sleeve area insulated via PTFE bellows
83150 <i>Click-on</i> 	Seat valves	Directly solenoid actuated	DN 2,5 ... 4,5	125°C	0 ... 12 bar	PPSU (Polyphenylsulfon)	For materials in contact with media 
8590440 <i>Click-on</i> 	Seat valves	Directly solenoid actuated	DN 2,2 ... 2,5	125°C	0 ... 16 bar	PPSU (Polyphenylsulfon)	For materials in contact with media 

# Valves for drinking water applications

Series	Type	Operation	Orifice (mm)	Fluid temp. (Max.)	Pressure range	Material body	Features
82510 	Seat valves	Directly solenoid actuated	DN 1,5 ... 5	90°C	0 ... 40 bar	Brass (CW617N)	Optimized opening and closing time <b>KTW-approved sealing material</b>
82530 	Diaphragm valves	Solenoid actuated, with forced lifting	DN 10	90°C	0 ... 10 bar	Brass (CW617N), PA 66	Compact design by high flow rate <b>KTW-approved sealing material</b>
82400 <i>Click-on</i> 	Diaphragm valves	Indirectly solenoid actuated	DN 8 ... 50	90°C	0,1 ... 16 bar	Brass (CW617N)	Optional: Medium isolated by pilot control <b>KTW-approved sealing material</b>
82540 <i>Click-on</i> 	Diaphragm valves	Solenoid actuated, with forced lifting	DN 8 ... 50	90°C	0 ... 16 bar	Brass (CW617N)	For systems with low or fluctuating pressure <b>KTW-approved sealing material</b>
84070 	Diaphragm valves	Indirectly solenoid actuated	DN 12 ... 20	50°C	0,3 ... 10,5 bar	PPO GF 30	High-grade plastic valves <b>NSF-approval</b>
83150 <i>Click-on</i> 	Seat valves	Directly solenoid actuated	DN 2,5 ... 4,5	125°C	0 ... 12 bar	PPSU (Polyphenylsulfon)	For materials in contact with media <b>FDA and WRAS certified</b>
8590440 <i>Click-on</i> 	Seat valves	Directly solenoid actuated	DN 2,2 ... 2,5	125°C	0 ... 16 bar	PPSU (Polyphenylsulfon)	For materials in contact with media <b>FDA and WRAS certified</b>

# Special solutions

## 2/2-way valves 8499984.0000.00000

- > Special diaphragm valves DN 8
- > Wetted sealing materials
- > Drinking water safe
- > Compliance with KTW recommendations and DVGW worksheet

## 2/2-way valves 8499986.8264.XXXXX

- > Special bellows valves DN 4,5
- > Wetted sealing materials
- > Drinking water safe
- > Compliance with KTW recommendations and DVGW worksheet
- > Sleeve area insulated
- > Valves withstand up to 10 bar of counter-pressure

## 2/2-way valves 8590005.8264.XXXXX

- > Special bellows valves DN 3,5
- > Vent hole & sleeve area insulated
- > Valves withstand up to 10 bar of counter-pressure
- > Also available in stainless steel



Operating pressure  
-0,9 ... 6 bar



Operating pressure  
0 ... 1,5 bar



Operating pressure  
0 ... 3 bar

**2/2-way valves**  
8499985.8083.XXXXX

- > Special diaphragm valves DN 5
- > Wetted sealing materials
- > Drinking water-safe
- > Compliance with KTW recommendations and DVGW worksheet
- > Sleeve area insulated

**2/2-way valves**  
8591003.8476.XXXXX

- > Special diaphragm valves DN 25
- > Wetted sealing materials
- > Drinking water-safe
- > Compliance with KTW recommendations and DVGW worksheet
- > Protected sleeve area by flat diaphragm

**4-fold-valve-manifold**  
8590380.9840.XXXXX

- > Seat valves DN 3,5



Operating pressure  
0 ... 0,2 bar



Operating pressure  
0 ... 0,1 bar

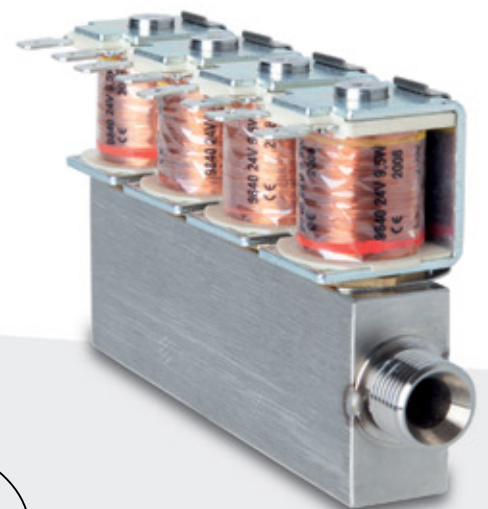

Operating pressure  
0 ... 3 bar

Please get in touch to  
find out more!

# Special solutions

2-fold-solenoid-valve-manifold  
859XXXX.XXXX.XXXXX  
with integrated mixing nozzles

> Seat valves DN 2,5

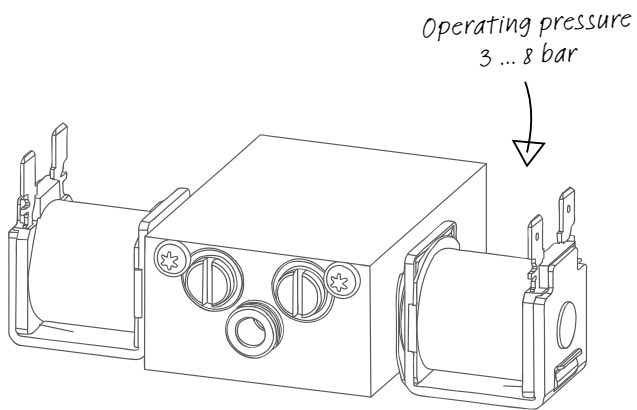

2/2-way valves  
84070XX.9101.XXXXX

> Diaphragm valves DN 12

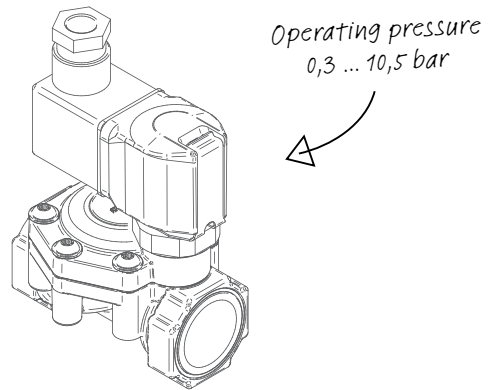

2-fold-solenoid-valve-manifold  
859XXXX.XXXX.XXXXX

- > Bellow valves DN 4,5
- > Suitable for slightly aggressive media
- > Seat seal FFPM
- > Sleeve area insulated

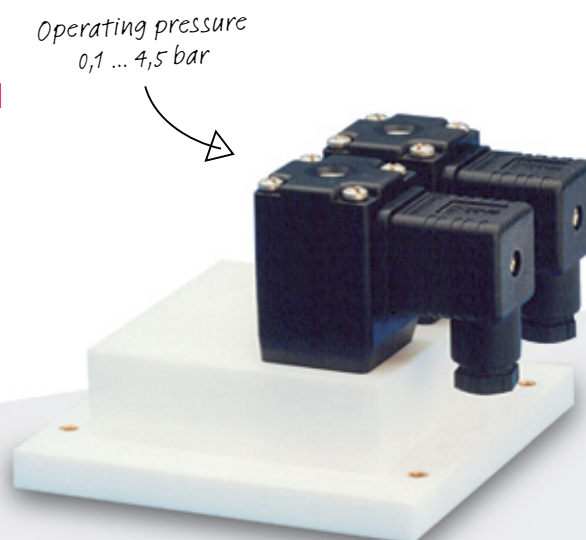





PRO GF 30

High grade plastic



Valves with NSF-approval

*Single or  
interlinkable!!*

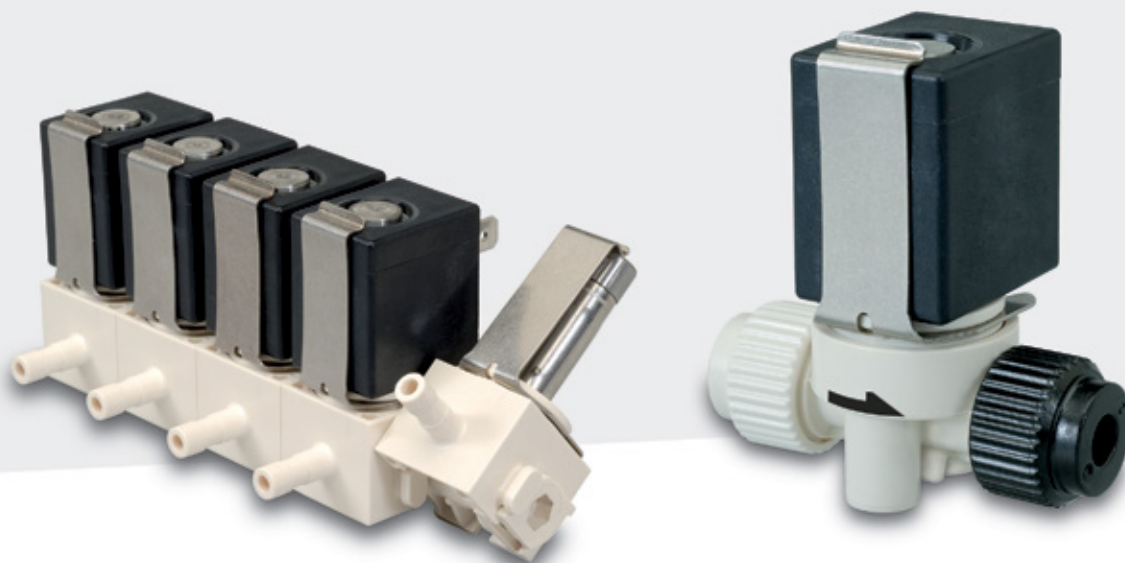

## Applications

### Beverage dispense

- > Coffeemachines
- > Drinking water dispenser
- > Vending machines
- > Cold- & hot water devices and milk warmer
- > Softdrink machines
- > Cream & ice machines





### Water treatment

- > Discharge control
- > Filtration plants
- > Desalination of seawater
- > Pumping stations

### Water purification

- > Treatment
- > Ventilation
- > Dosing

  
*Usable areas*



IMI Precision Engineering operates four global centres of technical excellence and a sales and service network in 50 countries, as well as manufacturing capability in the USA, Germany, China, UK, Switzerland, Czech Republic, Mexico and Brazil.

For information on all IMI Precision Engineering companies visit

[www.imi-precision.com](http://www.imi-precision.com)

**Supported by distributors worldwide.**

# IMI

**Precision Engineering**

Norgren, Buschjost, FAS, Herion and Maxseal are registered trademarks of IMI Precision Engineering companies.

Due to our policy of continuous development, IMI Precision Engineering reserve the right to change specifications without prior notice.

z8244BR en/05/19

Selected Images used under license from Shutterstock.com

*Engineering  
GREAT  
Solutions*

 **IMI NORGREN**

 **IMI BUSCHJOST**

 **IMI FAS**

 **IMI HERION**

 **IMI MAXSEAL**

For further information, scan this QR code or visit [www.imi-precision.com](http://www.imi-precision.com)

